

PLAN

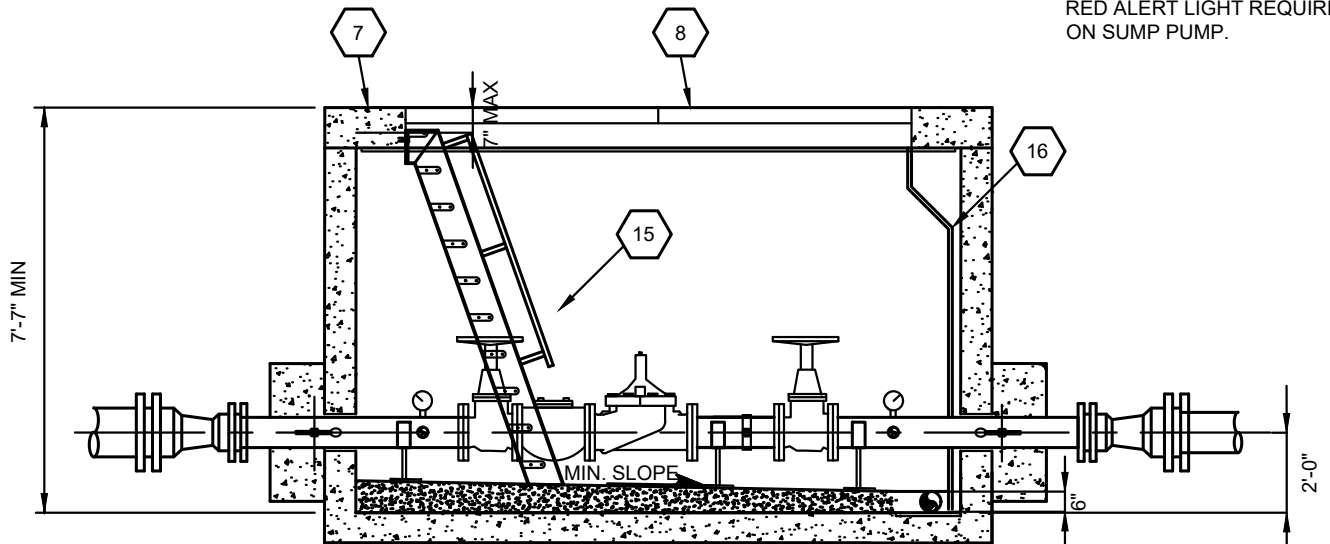

A SECTION

NOTE:

ALTERNATE TO FIELD ASSEMBLED PRV AND VAULT IS SYSTEM AS MANUFACTURED BY GC SYSTEMS.

(X) SEE W18B FOR CALLOUTS AND NOTES



PRESSURE REDUCING VALVE AND VAULT

DATE: 11-2022

DWG: W18A