

**VALVE BOX IN  
ASPHALT AREA**

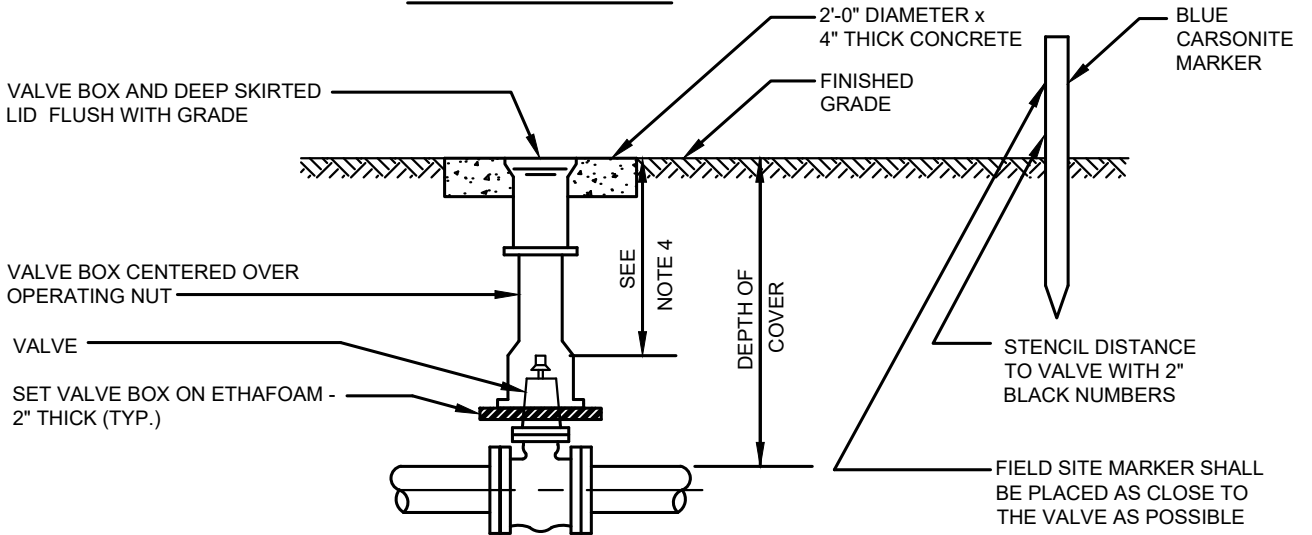

**VALVE BOX IN  
UNIMPROVED AREA (VALVE MARKER REQUIRED)**

**NOTES:**

1. EACH VALVE SHALL BE PROVIDED WITH AN ADJUSTABLE CAST IRON VALVE BOX OF 5 INCHES (5") INSIDE DIAMETER. VALVE BOXES SHALL HAVE A TOP SECTION WITH AN EIGHTEEN INCH (18") MIN. LENGTH.
2. VALVE BOX COVERS ARE BASED ON DIFFERENT SPEED ROADWAYS AS FOLLOWS:

VALVE BOX COVER BASED ON ROADWAY SPEED		
	25 MPH OR LESS	25 MPH OR GREATER
VALVE BOX TOP	EAST JORDAN NO. 85557016	EAST JORDAN NO. 85557016
VALVE BOX COVER	EAST JORDAN NO. 06800001 OLYMPIC FOUNDARY NO. 940	EAST JORDAN NO. 06800045
VALVE BOX BOTTOM	EAST JORDAN NO. 85556024U	EAST JORDAN NO. 85556024U

3. 18" MINIMUM, 24" MAXIMUM FOR OPERATOR NUT IF EXTENSION IS REQUIRED, SEE DETAIL W6.
4. VALVE BOX EARS OR NOTCHES SHALL BE PLACED IN LINE WITH THE PIPE IT SERVES.



**Silver Lake Water & Sewer District**

---

**VALVE BOX**

---

DATE: 11-2022	DWG:W4
---------------	--------